

The theory of polynomial-like mappings – The importance of quadratic polynomials

Núria Fagella

Univ. Autònoma de Barcelona
nuria mat.uab.es

1 Introduction

In the field of complex dynamics and, in particular, iteration of functions of one complex variable, the topic that has by far been object of the most attention is the iteration of the family of quadratic polynomials $Q_c := z^2 + c$. In this paper we aim to answer the question of why this very particular family of polynomials is important for the understanding of iteration of general complex functions.

This is the third paper in the “Complex Dynamics” series of EWM 95. We assume that the reader is familiar with the basic definitions and theorems concerning the dynamics of quadratic polynomials which are the topic of the first article [Br3]. For other surveys we refer also [Bl1, Br1] and [Mi].

As a first observation we may say that often, a good place to start is the simplest example, in this case the group of Möbius transformations which are already very well understood. The next simplest class of functions is the class of polynomials of degree two and even that early along the way, we already bump into complicated dynamics which have occupied mathematicians in this field for over twenty years, and still do.

But the real answer to the question has basically one name and that is *the theory of polynomial-like mappings* of A. Douady and J. Hubbard. This theory explains how the understanding of polynomials is not only interesting *per sé*, but helps understand a much wider class of functions namely those that locally behave as polynomials do.

Most of the definitions and results in this paper may be found in the work of Douady and Hubbard “*On the Dynamics of Polynomial-like Mappings*” [DH3]. Our goal is to state their most important results as well as to give several examples that illustrate them. These examples serve also as initial motivation: example B concerns families of cubic polynomials whose dynamical planes exhibit homeomorphic copies of quadratic filled Julia sets (see Figs. 5 and 6), while their parameter spaces contain homeomorphic copies of the Mandelbrot set (see Fig. 12); example C deals with the family of entire transcendental functions $f_\lambda(z) = \lambda \cos(z)$ for which the same phenomena occur (see Figs. 7 and 13); finally, example D shows how we find copies of the Mandelbrot set in the Mandelbrot set itself (see Figs. 8, 9 and 14). Examples of the same phenomena for Newton’s method may be found in [BC, CGS, DH3, T] and in [F] for the family $z \mapsto \lambda ze^z$.

This work is divided in two parts, the first one concerning the dynamical planes and the second one the parameter spaces. Section 2.1 contains the definition of a polynomial-like map and sets up the examples that we follow throughout the paper. In Section 2.3 we state the straightening theorem (Theorem 2.2) which explains how polynomial-like maps and actual polynomials are related. Along the way, we give a small survey of the different types of conjugacies that may occur. Section 3 contains the parameter-plane version of the straightening theorem, explaining why we find homeomorphic copies of the Mandelbrot set in the parameter planes of other families of functions.

Figure 12 was borrowed from [Br2] by courtesy of Bodil Branner. All other computer illustrations in this paper were created with the program *It* by Christian Mannes, whom I thank for assistance and patience.

2 Dynamical Plane

2.1 The Definition of a Polynomial-like Map

Definition A *polynomial-like map* of degree $d \geq 2$ is a triple (f, U', U) where U and U' are open sets of \mathbb{C} isomorphic to discs with $\overline{U'} \subset U$ and $f : U' \rightarrow U$ is a holomorphic map such that every point in U has exactly d preimages in U' when counted with multiplicity.

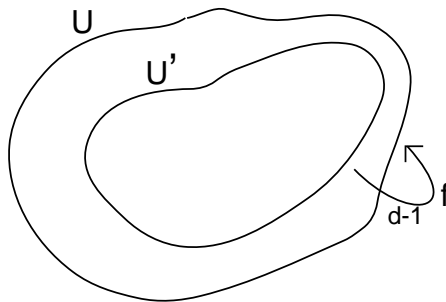

Figure 1: The three elements (f, U', U) that form a polynomial-like map.

Example A The obvious example is an actual polynomial of degree d , restricted to a large enough open set. Let P be a polynomial of degree $d \geq 2$ and let Γ' be an equipotential curve of P of some given potential η (see [Br3]) such that it is a single simple curve. Then, $\Gamma := P(\Gamma')$ is an equipotential curve of potential $d\eta$. If we let U' and U be the open sets enclosed by Γ' and Γ respectively then, the triple $(P|_{U'}, U', U)$ is a polynomial like map (see fig. 2). Note that we do not necessarily have to choose the open sets as regions enclosed by equipotentials. In fact, if we let V' be any large enough disk then $V := P^{-1}(V')$ is an open set contained in V and $(P|_{V'}, V', V)$ is *another* polynomial-like map.

Example B In this example we want to consider some polynomials of degree three which restricted to an open set form a polynomial-like map of degree two. Let P be a cubic polynomial with one critical point ω_1 escaping to infinity under iteration and the other one, ω_2 , remaining bounded. Let Γ be the equipotential curve that has the critical value $v_1 := P(\omega_1)$ as one of its points and let U be the open set bounded by Γ . Then, the preimage of Γ under P is a figure eight curve, since all points on Γ have three preimages with the exception of the critical value v_1 that has only two preimages (see fig. 3). This figure eight bounds two connected components. Let U' be the open connected component that contains

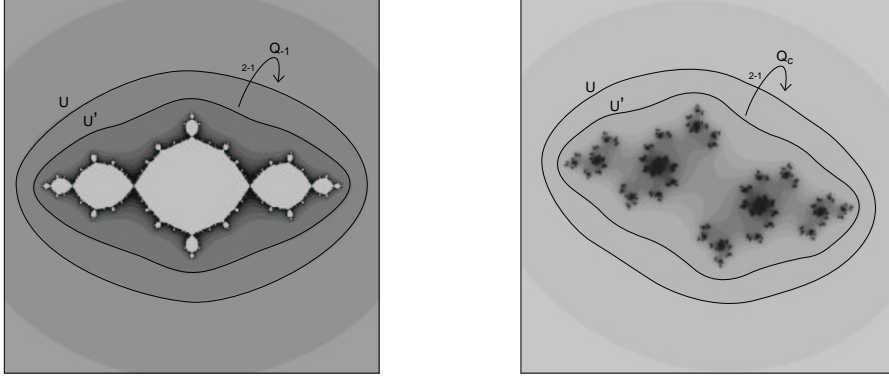

Figure 2: The restriction of two polynomials of degree two as polynomial-like maps. Left: $Q_{-1}(z) = z^2 - 1$ with connected Julia set. Right: $Q_c(z)$ where $c \simeq -0.8 + 0.4i$, with totally disconnected Julia set.

the critical point ω_2 with a bounded orbit. Then, U' maps to U with degree two, i.e., every point in U has exactly two preimages in U' . The triple $(P|_{U'}, U', U)$ is a polynomial-like map of degree two. (Notice that if we choose sets U' and U as we did in example A, we would obtain a polynomial-like map of degree three.) We have chosen a polynomial of degree three for the sake of the example but it is clear that similar situations would occur with polynomials of any degree, with critical points escaping and not escaping to infinity.

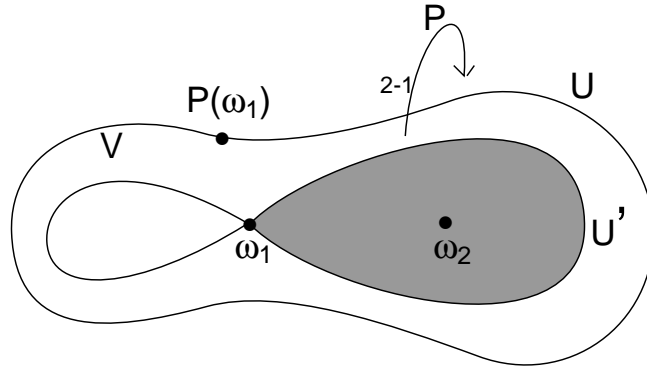

Figure 3: The restriction of a cubic polynomial to create a polynomial-like map of degree two.

Example C Let $f(z) = \pi \cos(z)$ and let U' be the open simply connected domain

$$U' = \{z \in \mathbb{C} \mid |\operatorname{Im}(z)| < 1.7, |-\pi - \operatorname{Re}(z)| < 2\},$$

and set $U = f(U')$. One can check that $\overline{U'} \subset U$, as shown in Fig. 4. Since U' contains only one critical point $\omega = -\pi$, it follows that f maps U' to U with degree two. Hence the triple $(f|_{U'}, U', U)$ is a polynomial-like of degree two.

Example D Sometimes a polynomial-like map is created as some iterate of a function restricted to a domain. For example, let $Q_c(z) = z^2 + c$ and let $c_0 \simeq -1.75778 + 0.0137961i$. Set

$$U' = \{z \in \mathbb{C} \mid |\operatorname{Im}(z)| < 0.2, |\operatorname{Re}(z)| < 0.2\}.$$

One can check that the polynomial $Q_{c_0}^3$ maps U' onto a larger set U with degree 2, as shown in Fig. 4. The triple $(Q_{c_0}^3|_{U'}, U', U)$ is a polynomial-like map of degree two.

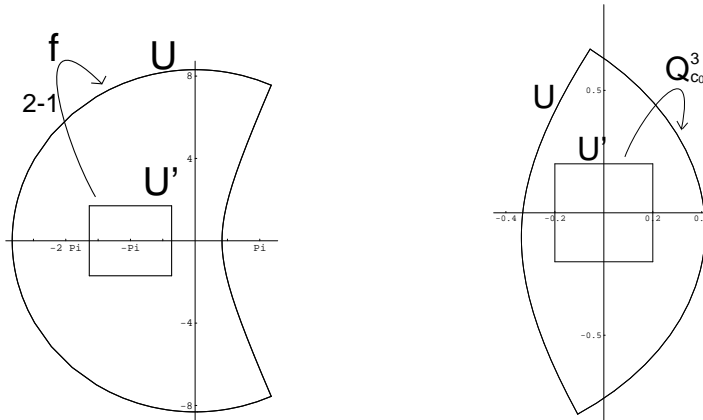

Figure 4: The restriction of $f(z) = \pi \cos(z)$ (left) and $Q_{c_0}^3(z)$ (right) to create polynomial-like maps of degree two.

This is an example of what is called *renormalization*. We say that a quadratic polynomial is *renormalizable* if there exist open disks U' and U and an integer n such that $(f^n|_{U'}, U', U)$ is polynomial like of degree two. Renormalization is a very important topic in the field of complex dynamics. (See [Mc]).

2.2 The Filled Julia Set

The *filled Julia set* and the *Julia set* are defined for polynomial-like maps in the same fashion as for polynomials, keeping in mind that a polynomial-like map is defined only in an open subset of \mathbb{C} .

Definition Let $f : U' \rightarrow U$ be a polynomial-like map. The *filled Julia set* of f is defined as the set of points in U' that never leave U' under iteration, i.e.,

$$K_f := \{z \in U' \mid f^n(z) \in U' \text{ for all } n \geq 0\}.$$

An equivalent definition is

$$K_f = \bigcap_{n \geq 0} f^{-n}(\overline{U'}),$$

and from this expression it is clear that K_f is a compact set.

As for polynomials, we define the *Julia set of f* as

$$J_f := \partial K_f.$$

Notice that if the map f is the restriction of some polynomial F to a set U' then, in general, $K_f \subsetneq K_F$. As an example consider example B above where F is a polynomial of degree three and f its restriction to the set U' in Fig. 3. Notice that U' maps to U with degree two. The other connected component of $F^{-1}(U)$ which we denote by V , maps to U with degree one. Hence, there are points in U' that map to V and come back to U' afterwards,

never leaving the set U . Such points do not belong to K_f since they are not in U' at all times but they belong to K_F since they do not escape to infinity under iteration. Hence $K_f \subsetneq K_F$ and moreover, a connected component C of K_F is either a connected component of K_f or it is disjoint from K_f , since F maps connected components of K_F to connected components. Therefore K_F might have more connected components than K_f but not larger ones.

2.3 The Relation with Polynomials

The Straightening Theorem stated in this section shows that the relation between polynomial-like maps and actual polynomials is actually very strong. In order to state it, we need to review the different types of equivalences between holomorphic maps.

2.3.1 Equivalences or conjugacies of maps

Suppose $f : U' \rightarrow U$ and $g : V' \rightarrow V$ are two polynomials-like maps of degree d . The weakest, but very important equivalence between f and g is what we call *topological equivalence* or *topological conjugacy* and denote by \sim_{top} .

Definition We say that $f \sim_{\text{top}} g$ if there exists φ a homeomorphism from a neighborhood $N(K_f)$ of K_f to a neighborhood $N(K_g)$ of K_g such that the following diagram

$$\begin{array}{ccc} N'(K_f) & \xrightarrow{f} & N(K_f) \\ \varphi \downarrow & & \downarrow \varphi \\ N'(K_g) & \xrightarrow{g} & N(K_g) \end{array}$$

commutes, where $N'(K_f) \subset N(K_f)$ and $N'(K_g) \subset N(K_g)$.

If two functions are topologically conjugate, their dynamics are qualitatively “the same”, since the conjugacy φ must map orbits of f to orbits of g , periodic points of f to periodic points of g , critical points of f to critical points of g , etc. In particular, K_f must be mapped to K_g , but since φ is only a homeomorphism these sets could look quite different. For example, all quadratic polynomials that belong to a given hyperbolic component of the Mandelbrot set (except the center) are topologically equivalent. All polynomials in the complement of the Mandelbrot set are also topologically conjugate. (In fact, these conjugacies are global conjugacies. See remark below.)

On the other hand, the strongest type of equivalence between two holomorphic maps is *conformal equivalence*, due to the rigidity of holomorphic maps.

Definition We say that $f \sim_{\text{conf}} g$ if $f \sim_{\text{top}} g$ and the homeomorphism φ is conformal.

Remark 2.1 If we were dealing with maps defined in the whole complex plane we could consider also global conjugacies between them. In such a case, if two maps are conformally conjugate then they must be conjugate by an affine map $\varphi(z) = az + b$, since isomorphisms from \mathbb{C} to itself are affine. For the quadratic family, one can easily check that there is a unique representative in each affine class, that is, if Q_{c_1} and Q_{c_2} are affine conjugate, then $c_1 = c_2$.

The concept of *quasi-conformal maps* appears when we want to consider conjugacies that are stronger than topological, but weaker than conformal.

Quasi-conformal mappings For a homeomorphism, we do not have any control whatsoever in how angles are distorted. On the other hand, conformal maps have to preserve angles. Intuitively, a map is quasi-conformal if we have some control on the distortion of angles even if these are not preserved, i.e. the distortion of angles is bounded.

The precise definition is very intuitive if we assume that the map is differentiable. This is not such a crude assumption given the fact that quasi-conformal maps are differentiable almost everywhere. If φ is a diffeomorphism, the tangent map at a given point z_0 , takes a certain ellipse in the tangent space at z_0 to a circle in the tangent space at $\varphi(z_0)$. We define the *dilatation of φ at z_0* , $\mathcal{D}_\varphi(z_0)$, as the quotient of the length of the major axis over the length of the minor axis of this ellipse.

Definition Let $\varphi : U \rightarrow V$ be a diffeomorphism and $\mathcal{D}_\varphi = \sup_{z \in U} \mathcal{D}_\varphi(z)$. Then, φ is K -quasi-conformal if $\mathcal{D}_\varphi \leq K < \infty$.

If we do not assume the map to be differentiable, we can express its distortion in terms of moduli of annuli.

Definition Let φ be a homeomorphism. Then, φ is K -quasi-conformal if for all annuli A in the domain

$$\frac{1}{K} \text{mod}(A) \leq \text{mod}(\varphi(A)) \leq K \text{mod}(A)$$

Note that a map is 1-quasi-conformal if and only if it is conformal.

For those that prefer analytic definitions one can define quasi-conformal maps as follows:

Definition Let φ be a homeomorphism. Then φ is K -quasi-conformal if locally it has distributional derivatives in L^2 and the *complex dilatation* $\mu(z)$ defined locally as

$$\mu(z) \frac{d\bar{z}}{dz} = \frac{\bar{\partial}_z \varphi}{\partial_z \varphi} = \frac{\frac{\partial \varphi}{\partial \bar{z}} d\bar{z}}{\frac{\partial \varphi}{\partial z} dz}$$

satisfies $|\mu| \leq \frac{K-1}{K+1} := k < 1$ almost everywhere.

For more on quasi-conformal mappings see [A] and [LV].

Quasi-conformal conjugacies and hybrid equivalences We define a *quasi-conformal conjugacy* ($f \sim_{\text{qc}} g$) by requiring the homeomorphism φ in the topological conjugacy to be K -quasi-conformal for some $K \geq 1$. We say that f and g are *hybrid equivalent* ($f \sim_{\text{hb}} g$) if they are quasi-conformally conjugate and the conjugacy φ can be chosen so that $\bar{\partial}_z \varphi = 0$ almost everywhere on K_f . If J_f has measure zero, this simply means that φ is holomorphic in the interior of K_f . Clearly

$$f \sim_{\text{conf}} g \implies f \sim_{\text{hb}} g \implies f \sim_{\text{qc}} g \implies f \sim_{\text{top}} g.$$

2.3.2 The Straightening Theorem

The relation between polynomial-like mappings and actual polynomials is explained in the following theorem, whose proof can be found in [DH3].

Theorem 2.2 *Let $f : U' \rightarrow U$ be a polynomial-like map of degree d . Then, f is hybrid equivalent to a polynomial P of degree d . Moreover, if K_f is connected, then P is unique up to (global) conjugation by an affine map.*

This theorem explains why one finds copies of Julia sets of polynomials in the dynamical planes of all kinds of functions. Notice that if f is polynomial-like of degree two and K_f is connected then f is hybrid equivalent to a polynomial of the form $Q_c(z) = z^2 + c$ for a unique value of c by remark 2.3.1. This may also be true for other families of polynomial-like maps of degree larger than two, as long as the resulting class of polynomials has a unique representative in each affine class. (As examples, consider the families $\lambda z(1+z/d)^d$, $\lambda \in \mathbb{C} \setminus \{0\}$ for any $d > 2$).

Example B.1 In the setting of example B in Sect.2.1, we consider the polynomial $P_a(z) = z^3 - 3a^2z - 2a^3 - a$. One can check that for all values of a , the critical point $\omega_2 = -a$ is a fixed point. If we take, for example, $a = -0.6$ then the critical point $\omega_1 = a$ escapes to infinity. By the Straightening Theorem, $P_{-0.6}(z)$ restricted to the open set U' as defined in example B, is hybrid equivalent to a quadratic polynomial and hence, to a polynomial of the form $Q_c(z) = z^2 + c$. In this case, we know that the parameter c must be 0, since $Q_0(z)$ is the only quadratic polynomial of this form with the critical point being fixed. In Fig. 5, we show the dynamical plane of Q_0 and that of $P_{-0.6}$.

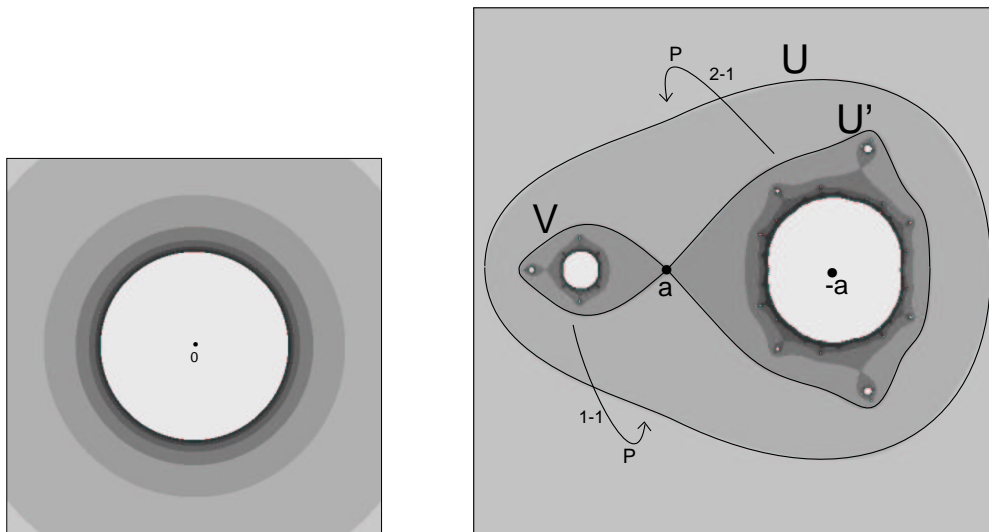

Figure 5: Left: the filled Julia set of $Q_0(z) = z^2$ in white. Right: the filled Julia set for $P_{-0.6}(z)$ in white. Note that only the largest component in U' corresponds to the filled Julia set of the polynomial-like map of degree 2.

Example B.2 Again in the setting of example B in sect. 2.1, we consider the polynomial $R_a(z) = z^3 - 3a^2z + (1/2)(\sqrt{9a^2 - 4} + a - 4a^3)$. One can check that for all values of a , the critical point $c_2 = -a$ is a point of period 2. In this case we take $a = -0.75$ and then, the critical point $c_1 = a$ escapes to infinity. By the straightening theorem, $R_{-0.75}(z)$ restricted to the open set U' as above, is hybrid equivalent to a quadratic polynomial and hence, to a

polynomial of the form $Q_c(z) = z^2 + c$. In this case, we know that the parameter c must be -1 , since $Q_{-1}(z)$ is the only quadratic polynomial of this form with the critical point being of period two. In Fig. 6, we show the dynamical plane of $R_{-0.75}$, to be compared with that of Q_{-1} in Fig. 2.

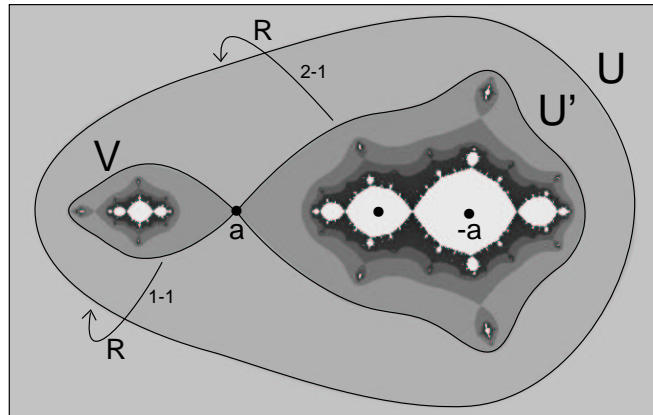

Figure 6: The filled Julia set for $R_{-0.75}$ in white. Note that only the largest component in U' corresponds to the filled Julia set of the polynomial-like map of degree 2. This figure is to be compared with Fig. 2 left.

Example C Even though the function $f(z) = \pi \cos z$ is an entire transcendental function, when restricted to the set U' (as defined in Sect. 2.1) it is a polynomial-like map of degree two. In Fig. 7, we see in white the set of points that do not escape to infinity (in the imaginary direction) under iteration of f . The largest component inside U' corresponds to the filled Julia set of the polynomial-like map. Since the critical point $-\pi$ is fixed under f , the filled Julia set is homeomorphic to that of $Q_0(z) = z^2$.

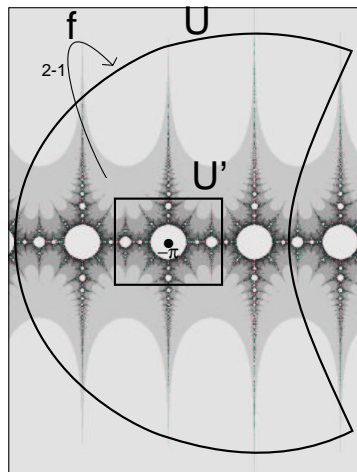

Figure 7: The largest white component in U' corresponds to the filled Julia set of $f(z) = \pi \cos z$ restricted to the set U' .

Example D Consider again $Q_{c_0}(z) = z + c_0$ where $c_0 \simeq -1.75778 + 0.0137961i$. As explained in Sect. 2.1, $Q_{c_0}^3$ maps the square box U' centered at 0 and with side length 0.4 onto a larger set U containing U' (see Fig. 4). By the Straightening Theorem, $Q_{c_0}^3$ is hybrid equivalent to

Q_c for some value of c . One can check that the critical point is periodic of period three under iteration of $Q_{c_0}^3$, hence there are a limited number of possibilities for c . In this case the filled Julia set of the polynomial-like map is homeomorphic to the Douady rabbit (see Figs. 8, 9).

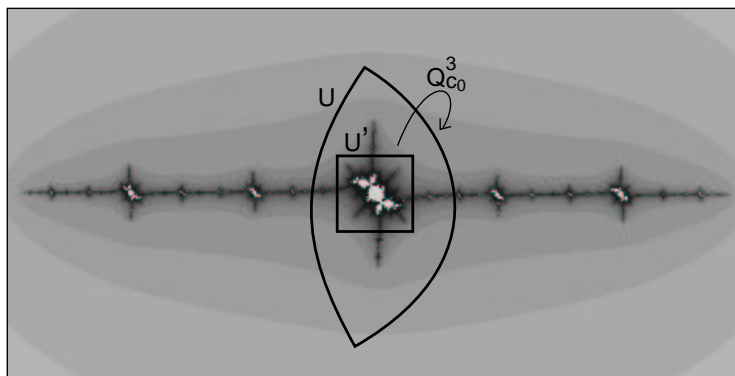

Figure 8: The filled Julia set of Q_{c_0} , where $c_0 \simeq -1.76 + 0.01i$.

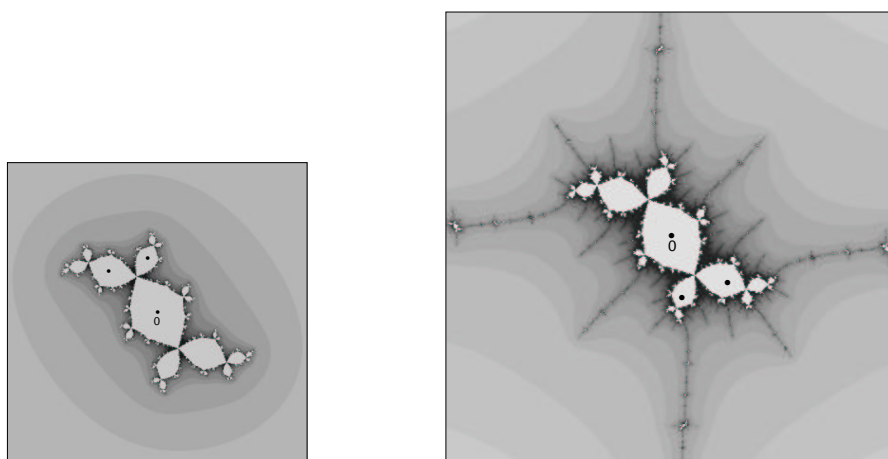

Figure 9: Left: the Douady rabbit or the filled Julia set of $Q_{c_1}(z) = z^2 - c_1$ in white, where $c_1 \simeq -0.122 + 0.745i$. Right: magnification of the filled Julia set of Q_{c_0} around the critical point. The copy of the Douady rabbit is the filled Julia set of the polynomial-like map corresponding to $Q_{c_0}^3$.

3 Parameter Plane

As usual, the phenomena in dynamical plane are reflected in parameter space. Recall that the parameter space of the family of quadratic polynomials $Q_c(z) = z^2 + c$ contains the *Mandelbrot set* defined as

$$M = \{c \in \mathbb{C} \mid \{Q_c^n(0)\}_{n \geq 0} \text{ is bounded} \}$$

or, equivalently, the set of c values for which the filled Julia set of Q_c is connected (see Fig. 10).

If we look at the parameter space for other functions, we very often encounter portions that resemble the Mandelbrot set. This fact is again explained by the theory of polynomial-like

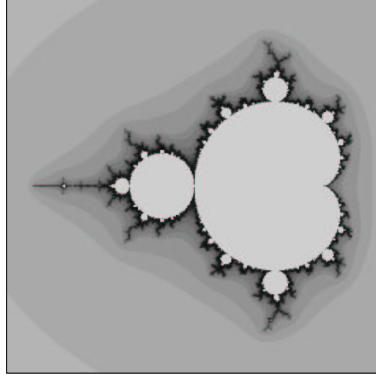

Figure 10: The Mandelbrot set

maps. Since the Mandelbrot set appears when we consider families of quadratic polynomials, it is reasonable to expect that it should also appear when we consider families of polynomial-like maps of degree two, as long as these families are “nice” enough.

Remark 3.1 For the sake of exposition, we consider here only one parameter families of polynomial-like mappings of degree two. For other cases see [DH3].

3.1 Analytic families of polynomial-like mappings

Definition Let Λ be a Riemann surface and $\mathcal{F} = \{f_\lambda : U'_\lambda \rightarrow U_\lambda\}$ be a family of polynomial-like mappings. Set

$$\begin{aligned}\mathcal{U} &= \{(\lambda, z) \mid z \in U_\lambda\} \\ \mathcal{U}' &= \{(\lambda, z) \mid z \in U'_\lambda\} \\ f(\lambda, z) &= (\lambda, f_\lambda(z))\end{aligned}$$

Then, \mathcal{F} is an analytic family of polynomial-like maps if it satisfies the following properties:

1. \mathcal{U} and \mathcal{U}' are homeomorphic over Λ to $\Lambda \times \mathbb{D}$
2. The projection from the closure of \mathcal{U}' in \mathcal{U} to Λ is proper
3. The map $f : \mathcal{U}' \rightarrow \mathcal{U}$ is holomorphic and proper

If these properties are satisfied, the degree of the maps is constant and it is called the degree of \mathcal{F} . We denote $K_\lambda = K_{f_\lambda}$ and $J_\lambda = J_{f_\lambda}$. By the Straightening Theorem, for each λ the map f_λ is hybrid equivalent to a polynomial of degree the degree of \mathcal{F} . By analogy with polynomials, we define

$$M_{\mathcal{F}} = \{\lambda \in \Lambda \mid K_\lambda \text{ is connected} \}.$$

In the next section, we give some conditions under which the set $M_{\mathcal{F}}$ is homeomorphic to the Mandelbrot set.

3.2 Homeomorphic Copies of the Mandelbrot Set

Let \mathcal{F} be an analytic family of polynomial-like maps of degree two. Then, for each $\lambda \in M_{\mathcal{F}}$, f_{λ} is hybrid equivalent to a unique polynomial of the form $Q_c(z) = z^2 + c$. Hence the map

$$\begin{aligned} \mathcal{C}: M_{\mathcal{F}} &\longrightarrow M \\ \lambda &\longmapsto c = \mathcal{C}(\lambda) \end{aligned}$$

is well defined.

Theorem 3.2 *Let $A \in \Lambda$ be a closed set of parameters homeomorphic to a disc and containing $M_{\mathcal{F}}$. Let ω_{λ} be the critical point of f_{λ} and suppose that for each $\lambda \in \Lambda \setminus A$, the critical value $f_{\lambda}(\omega_{\lambda}) \in U_{\lambda} \setminus U_{\lambda'}$. Assume also that as λ goes once around ∂A , the vector $f_{\lambda}(\omega_{\lambda}) - \omega_{\lambda}$ turns once around 0 (see Fig. 11). Then, the map \mathcal{C} is a homeomorphism and it is analytic in the interior of $M_{\mathcal{F}}$.*

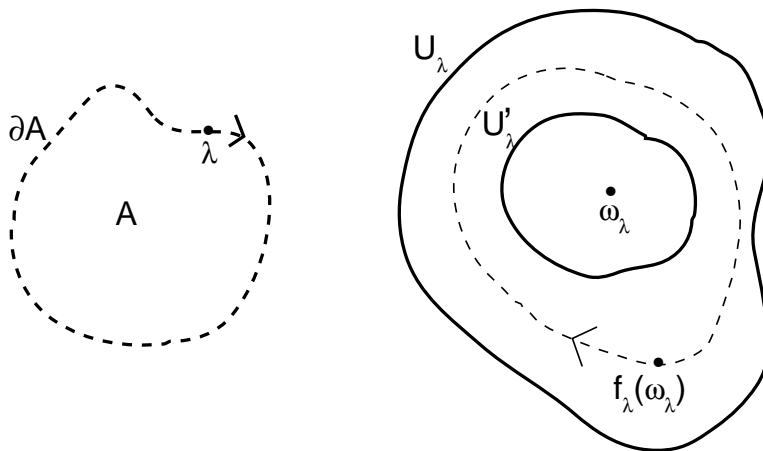

Figure 11: Illustration of theorem 3.2.

Remarks 3.3

1. The assumption “ $f_{\lambda}(\omega_{\lambda}) \in U_{\lambda} \setminus U_{\lambda'}$ if $\lambda \in \Lambda \setminus A$ ” is equivalent to $M_{\mathcal{F}}$ being compact.
2. If the winding number of $f_{\lambda}(\omega_{\lambda}) - \omega_{\lambda}$ around 0 is $\delta > 1$, then \mathcal{C} is a branched covering of degree δ .

Example A The purpose of this example is to illustrate that the conditions of the theorem are satisfied for the Mandelbrot set itself. Consider the parameter plane for the quadratic family and let

$$\Lambda = \{c \mid G_M(c) < 2\eta\} \quad A = \{c \mid G_M(c) \leq \eta\}$$

where G_M denotes the Green’s function of the Mandelbrot set. Given the way the Green’s function of M is defined, if $c \in \partial A$ then c lies on an equipotential curve of potential η in the dynamical plane as well. So, for each $c \in \partial A$, let Γ'_c and Γ_c be the equipotential curves in the dynamical plane of Q_c of potentials η and 2η respectively. The open sets enclosed by Γ'_c and Γ_c are the discs U'_c and U_c respectively and $\mathcal{F} = (Q_c|_{U'_c}, U'_c, U_c)$ the analytic family of polynomial-like maps. Note that, by construction, for each $c \in \Lambda \setminus A$, the critical value $Q_c(0) = c$ lies in $U_c \setminus U'_c$. Also, as c turns once around ∂A , the critical value c turns once

around the critical point 0. In this case $M_{\mathcal{F}} = M$.

Example B Consider the family of cubic polynomials $P(z) = P_{a,b}(z) = z^3 + az + b$. For any given constants ρ and θ we define the parameter space $\Lambda_\theta = \Lambda_{\rho,\theta}$ to be the set of polynomials P such that:

- one critical point ω_1 escapes to infinity with escape rate ρ
- another critical point ω_2 escapes to infinity at a slower rate or stays bounded
- the *co-critical point* ω'_1 of ω_1 that is, the other preimage of $P(\omega_1)$ different from ω_1 , belongs to the external ray $R(\theta)$ (see [Br3] for definitions of this terms and [Br2] for more in this example).

Note that polynomials of this type are polynomial-like maps of degree two, as shown in example B in Sect. 2.1. In [BH] Branner and Hubbard prove:

Theorem 3.4 *The parameter space Λ_θ is homeomorphic to a disc.*

Hence, polynomials in Λ_θ form a one-parameter family of polynomial-like maps of degree two.

Let $B_\theta = B_{\rho,\theta}$ be the set of polynomials in Λ_θ for which the orbit of ω_2 is bounded. Note that examples B.1 and B.2 are in B_θ for some values of ρ and θ . Also in [BH] we find the following theorem:

Theorem 3.5 *Let $\lambda \in B_\theta$ and suppose that the connected component of c_2 in $K(P_\lambda)$ is periodic. Then, the connected component of λ in B_θ is a homeomorphic copy of the Mandelbrot set.*

Figure 12 shows the parameter space Λ_0 with B_0 in black.

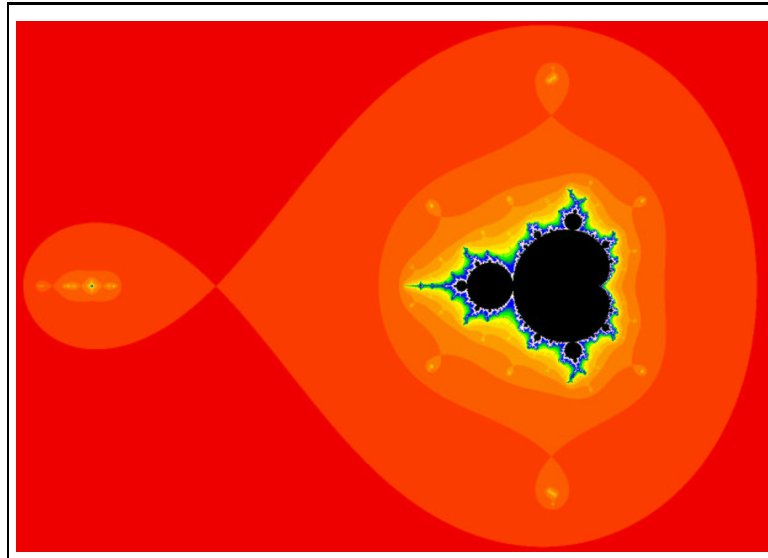

Figure 12: The set $B_0 \subset \Lambda_0$ shown in black, with countably many components which are homeomorphic copies of the Mandelbrot set.

Example C Let $f_\lambda(z) = \lambda \cos(z)$ and let A be an appropriately chosen disc in the λ -plane around $\lambda = \pi$. One can check that for appropriate choices of U'_λ and U_λ , the maps $(f_\lambda|_{U'_\lambda}, U'_\lambda, U_\lambda)$ form an analytic family of polynomial-like maps. As λ turns once around ∂A , the critical point stays fixed at $-\pi$ while the critical value $-\lambda$ winds once around $-\pi$ hence satisfying the conditions of theorem 3.2. In Fig. 13 we see the resulting copy of the Mandelbrot set, with $\lambda = \pi$ as the center of its main cardioid.

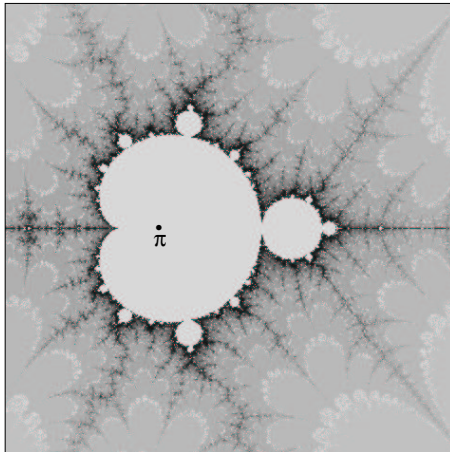

Figure 13: Copy of the Mandelbrot set in the parameter plane of $f_\lambda(z) = \lambda \cos z$.

Example D

Let $A \subset \Lambda$ be a small disc of parameters centered at $c \simeq -1.755$ and with c_0 contained in A where c_0 is as in example D in Sect. 2.1. For Q_{c^*} , the critical point is periodic of period three. One can check that for appropriate choices of λ , U_c , U'_c and A , the conditions of the theorem are satisfied for the family $\mathcal{F} = \{Q_c^3 : U'_c \rightarrow U_c\}_{c \in \Lambda}$. Figure 14 shows the Mandelbrot set and a magnification of the homeomorphic copy that contains c_0 .

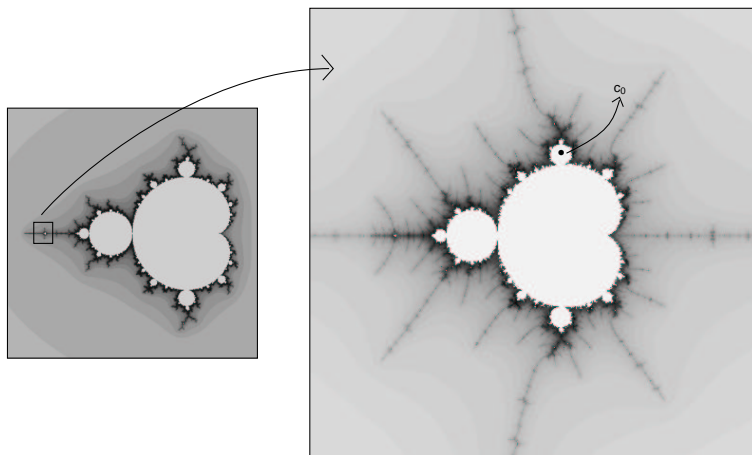

Figure 14: Copy of the Mandelbrot set in the parameter plane of Q_c . Range: $[-1.8, -1.72] \times [-0.038, 0.038]$.

References

- [A] L. Ahlfors, Lectures on Quasi-conformal Mappings, Van Nostrand, 1966.
- [Bl1] P. Blanchard, Complex Analytic Dynamics on the Riemann Sphere, *Bull. Amer. Math. Soc.* **11** (1984), 85-141.
- [Bl2] P. Blanchard, The Dynamics of Newton's Method, *Proc. Symp. Applied. Math.*, **49** (1994) 139-154.
- [BC] P. Blanchard & A. Chiu, Complex Dynamics: An Informal Discussion. Book chapter in Fractal Geometry and Analysis, ed. J. Bélair and S. Dubuc, Kluwer Academic Publishers (1991) 45-98.
- [Br1] B. Branner, The Mandelbrot Set, *Proc. Symp. Applied Math.*, (1989), 75-105.
- [Br2] B. Branner, Puzzles and para-puzzles of quadratic and cubic polynomials, *Proc. Symp. Applied. Math.*, **49** (1994) 31-69.
- [Br3] B. Branner, Holomorphic Dynamical Systems in the Plane – An introduction, EWM95.
- [BH] B. Branner & J. H. Hubbard, The Iteration of Cubic Polynomials. Part I: The Global Topology of Parameter Space, *Acta Mathematica*, **160**, (1988), 143-206.
- [CGS] J. Curry, L. Garnett & D. Sullivan, On the iteration of a rational function: Computer experiment with Newton's method, *Comm. Math. Phys* **91** (1983), 267-277.
- [DH1] A. Douady & J. Hubbard, Iterations des Polynomes Quadratiques Complexes, *C.R. Acad. Sci., Paris, Ser. I* **29** (1982), 123-126.
- [DH2] A. Douady & J. Hubbard, Etude dynamique des polynomes complexes, I,II, *Publ. Math. Orsay* (1984, 1985).
- [DH3] A. Douady & J. Hubbard, On the Dynamics of Polynomial-like Mappings, *Ann. Scient., Ec. Norm. Sup. 4^e series*, **18** (1985) 287-343.
- [F] N. Fagella, Limiting Dynamics of the Complex Standard Family, *Int. J. of Bif. and Chaos* (1995), To appear.
- [LV] O. Lehto & K. J. Virtanen, Quasi-conformal Mappings in the Plane, Springer-Verlag, 1973.
- [Mc] C. T. McMullen, Complex Dynamics and Renormalization, *Annals of Mathematics Studies*, 135, Princeton University Press, 1994.
- [Mi] J. Milnor, Dynamics on One Complex Variable: Introductory Lectures, IMS at Stony Brook Preprint n. 1990/5 (1992).
- [MSS] R. Mañé, P. Sad & D. Sullivan, On the Dynamics of Rational Maps, *Ann. Scie. École Norm. Sup.* (4) **16** (1983), 193-217.
- [T] Tan Lei, Cubic Newton's method of Thurston's type, preprint, Laboratoire de Math., École Norm. Sup. de Lyon.